

发行版本 Revision	修改内容 Description	制图 Drawing	日期 Date
A / 0	First release	Ding	2023.06.02

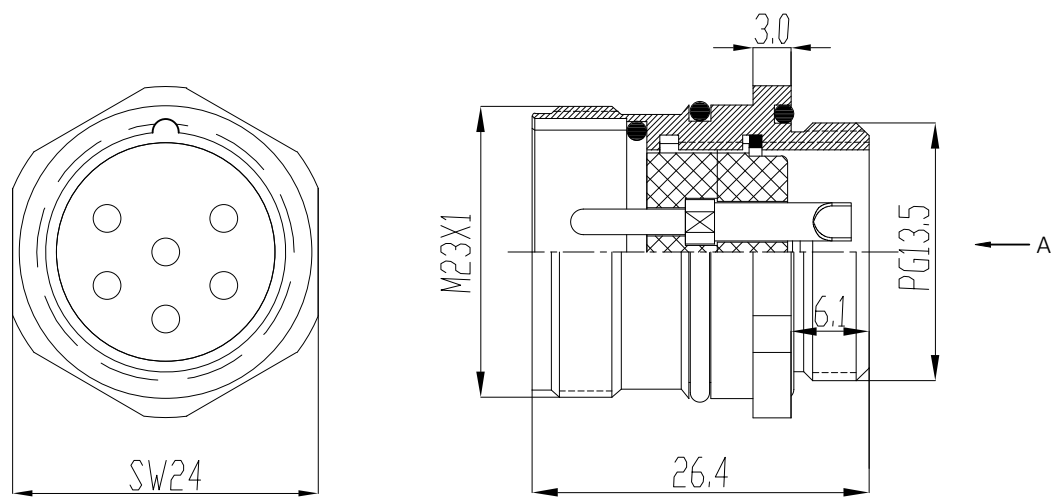

Pin Assignment
(Back View)

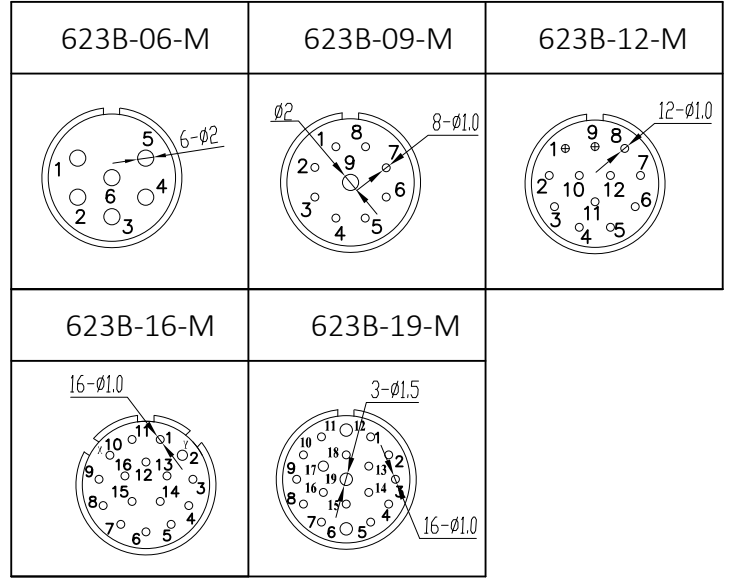

Technology parameter:

P/N	623B-06-M	623B-09-M	623B-12-M	623B-16M	623B-19-M
NO.of contacts	6	9	12	16	19
Rated current/voltage	20A/200V	8A/260V 20A/300V	8A/200V	8A/125V	8A/125V 20A/200V
Operation limit voltage(AC.V.rms)	250	250	250	200	200
Withstanding voltage (AC.V.rms) I minute	2500	2500	2500	2500	2500
Insulation resistance	≥100MΩ	≥100MΩ	≥100MΩ	≥100MΩ	≥100MΩ
Contact resistance	≤5mΩ	≤5mΩ	≤5mΩ	≤5mΩ	≤5mΩ
Solder cup mouth aperture	ø2.3	ø1.3 ø2.3	ø1.3	ø1.3	ø1.3
Contact diameter	ø2	ø1x8 ø2x1	ø1	ø1	ø1x1.6 ø1.5x3

- Material and specifications:
1. Coupling: Threaded coupling
 2. Shell material: Zinc alloy with nikelplate
 3. Insert material: PA66+GF
 4. Contact material: copper, gold-plated
 5. Termination: Solder
 6. Mating cycle: >500 cycles
 7. Temperature range: -40°C~+120°C
 8. Cable diameter: ø5mm~ø8mm

客户料号 Cus' P/N	图号 File No.	623B-xx-M	品名 Name	M23 Male connector Rear mount, solder type
未注公差 Unless Otherwise Specified		单位 Unit	mm	版本 Revision
A/0		比例 Scale	---	日期 Date
线性 Linear	0.5~6 ±0.1 >6~30 ±0.2 >30 ±2%	页码 Page	1/1	图纸确认 APPROVAL
角度 Angles	±3°	Third Angle Projection		日期 Date
				日期 Date
				日期 Date
				日期 Date