

4	5	6
发行版本 Revision	修改内容 Description	制图 Drawing
A / 0	First release	Ding
		日期 Date
		2023.06.02

Pin Assignment  
(Front View)

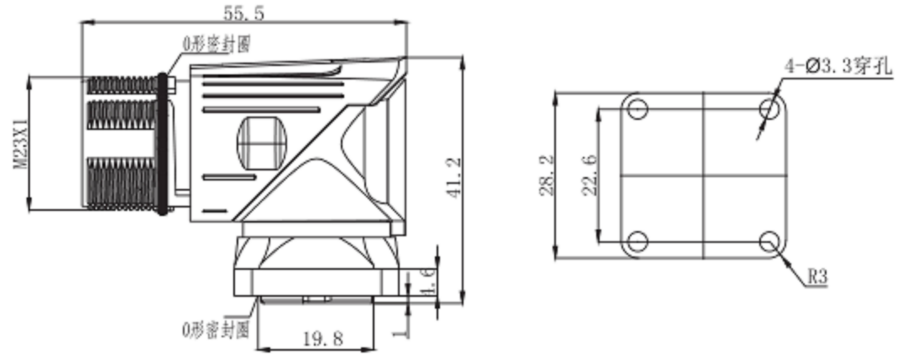
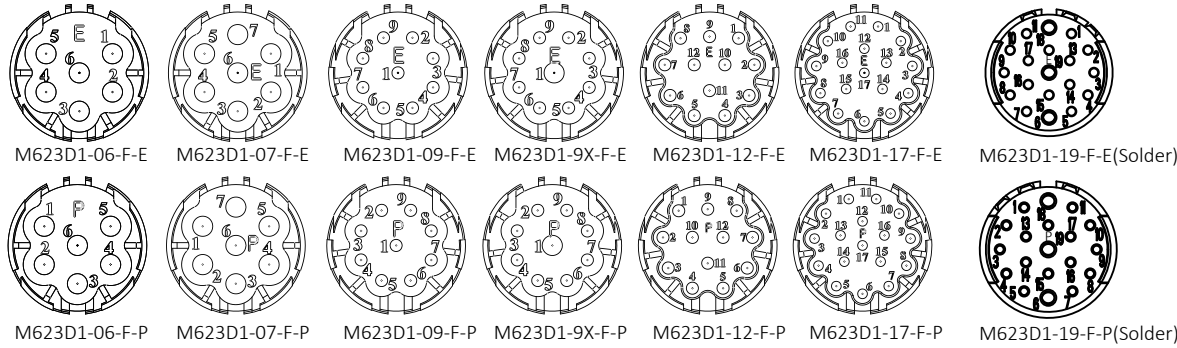

Technology parameter:

P/N	M623D1-06-F	M623D1-07-F	M623D1-09-F	M623D1-9X-F	M623D1-12-F	M623D1-17-F	M623D1-19-F
NO.of contacts	6	7	9	9X	12	17	19
Rated current/voltage	20A/300V	20A/300V	8A/300V	8A/260V 20A/300V	8A/260V	8A/260V	8A/125V 20A/200V
Operation limit voltage(AC.V.rms)	250	250	200	200	200	200	200
Withstanding voltage (AC.V.rms) 1 minute	2500	2500	2500	2500	2500	2500	2500
Insulation resistance	≥100MΩ	≥100MΩ	≥100MΩ	≥100MΩ	≥100MΩ	≥100MΩ	≥100MΩ
Contact resistance	≤5mΩ	≤5mΩ	≤5mΩ	≤5mΩ	≤5mΩ	≤5mΩ	≤5mΩ
Cup mouth aperture	∅2.4	∅2.4	∅1.3	∅1.3 ∅2.4	∅1.3	∅1.3	∅1.3
Contact diameter	∅2	∅2	∅1	∅1*8 ∅2*1	∅1	∅1	∅1*16 ∅1.5*3

Material and specifications:

1. Coupling: Threaded coupling
2. Shell material: Zinc alloy with nickelplate
3. Insert material: PA66+GF
4. Contact material: copper, gold-plated
5. Termination: Crimp(19P is Solder)
6. Mating cycle: >500 cycles
7. Temperature range: -25℃~+85℃

客户料号 Cus' P/N	图号 File No.			M623D1-xx-F-E/P	品名 Name	R/A M23 female connector With flange,Crimp type			
未注公差 Unless Otherwise Specified			单位 Unit	mm	版本 Revision	A/0	图纸确认 APPROVAL	日期 Date	
线性 Linear	0.5~6	±0.1	比例 Scale	---	 Third Angle Projection	绘图 Drawing	Ding	2023.06.02	
	>6~30	±0.2				审核 Checked	Jim	2023.06.02	
角度 Angles	±3°		页码 Page	1/1	客户确认 Customer Approved				